

**CONTRACTING AUTHORITY**

Business company: **Unipetrol Centre for Research and Education, a. s.**  
Registered office at: Revoluční 1521/84, 400 01 Ústí nad Labem  
Represented by: Ing. František Svoboda, Chairman of the Board and  
doc. Ing. Jaromír Lederer, CSc., Vice-Chairman of the Board  
Telephone: 475 309 222  
ID Nr./Tax ID. Nr: 62243136 / CZ62243136, VAT payer  
Bank details: Komerční banka Ústí nad Labem, account number: 7009 – 411/0100

**INVITATION TO SUBMIT THE BIDS AND TENDER  
DOCUMENTATION****For the below-threshold public contract titled ‘Continual  
Distillation’,**

Financed from public resources. This public contract is a below-threshold public contract as per § 26 Act No. 134/2016 Coll., on Public Procurement Act, as amended (hereinafter referred to as the “PPA”) and it is assigned according to simplified below-threshold procedure as per § 53 and PPA.

(hereinafter referred to as the ‘**Tender documentation**’)

**1. Information on the type, and subject of the public contract**

Public contract title: **Continual distillation**  
**Estimated value:** **5,000,000 CZK excluding VAT**  
**Public contract type:** **Public contract for the supplies**  
Result of the tender proceeding: Contract conclusion with one selected bidder  
Expected fulfilment commencement: 2. Q 2018  
Mode of public contract: sublimit contract  
  
Code of the public contract subject matter  
Classification as per CPV: 42910000-8 Distillation, filtration, and rectification  
device  
42912340-7 Distillation device  
  
Possible variants of the bid: No  
The contract division in parts: No

The Public Contract fulfilment forms a part of the implementation of the project ‘The Development of Research Infrastructure CATPRO’, implemented within the program ‘Operation Program Research, Development, and Education’ (OP RDE) with financial support from European Union, and state budget of the CR – the operation program is managed by Ministry of Education, Youth, and Sports of the Czech Republic. The fulfilment of the public contract shall be also partially financed from the sources of the Ministry of Industry and Trade of the Czech Republic, specifically from Institutional support, eventually from own sources of the Contracting Authority.

The subject matter of the public procurement fulfilment is:

- 1.1. the supply of the **Distillation Apparatus for continual distillation**, with all parts and accessories, potentially other components, installation, commissioning and training of the operators, all according to the minimum technical specification defined in Annex no. 1 hereof.
- 1.2. out-of-warranty service of the supply subject matter provided solely upon explicit notice of the Contracting Authority.

The public contract shall be fulfilled under contract concluded according to the binding contract sample which forms annex no. 2 of the tender documentation.

## 2. Contact data of the Contracting Authority:

The main contact person: Ing. Veronika Vavroušková  
email: [veronika.vavrouskova@unicre.cz](mailto:veronika.vavrouskova@unicre.cz)  
tel.: +420 471 122 305

Deputy of the main contact person: Ing. Ladislav Kudrlička  
email: [ladislav.kudrlicka@unicre.cz](mailto:ladislav.kudrlicka@unicre.cz)  
tel.: +420 475 309 229

In case of electronic communication, the Contracting Authority recommends communicating with both contact persons.

The mail address for delivering mail from the bidder to the Contracting Authority during the tender procedure:

Unipetrol Centre for Research and Education, a. s.  
Revoluční 1521/84  
400 01 Ústí nad Labem  
Telephone: +420 475 309 222  
Fax: +420 475 212 079  
E-mail: [veronika.vavrouskova@unicre.cz](mailto:veronika.vavrouskova@unicre.cz),  
[ladislav.kudrlicka@unicre.cz](mailto:ladislav.kudrlicka@unicre.cz)

### **3. Term and place for bid submission**

Deadline for the submission of the bids: **27. 6. 2018 before 11:00 o'clock.**

Place for the submission of the bids:

**Unipetrol Centre for Research and Education, a. s.**

Revoluční 1521/84,

400 01 Ústí nad Labem

Personal delivery requires the above defined address for the bid submission, 1st floor, office 202 (secretariat of the director).

The bid can be submitted in person during working days from 8 AM to 3 PM, on the last day of the deadline for the bid submission from 8 AM to 11 AM o'clock. In case of delivery using a different method, the Contracting Authority must receive the bid at the latest on the last day of the deadline for the bid submission at the latest before 11 AM o'clock.

The decisive factor for the bid delivery is the moment of the bid reception by the Contracting Authority. In case of delivering the bid by mail or another similar method, the moment of delivering the bid is decisive, not e.g. the date of handing over the bid to the mail provider.

### **4. Requirements for proving the compliance with the qualification criteria**

The bidder who submits the bid within the tender procedure is obliged to prove the qualification fulfilment within the scope and method defined in this part of the tender documentation. The eligible bidder shall be eligible, provided that it:

- Prove the fulfilment of the general eligibility according to § 74 PPA;
- Prove the fulfilment of professional eligibility according to § 77 PPA;
- Prove the fulfilment of technical qualification according to § 79 PPA;

#### **4.1. General eligibility according to § 74, clause 1 letter a) - e) PPA;**

The bidder is eligible if it according to § 74 clause 1 PPA:

- a) has not been convicted by final judgement in the country of its registered seat of a crime specified in Annex No. 3 PPA or another similar crime pursuant to the law of the country of its registered office in the past five years preceding the commencement of the procurement procedure; expunged convictions are disregarded;
- b) has no outstanding tax arrears registered in tax records in the Czech Republic or in the country of its registered office;

- c) has no outstanding arrears in respect of payments and penalties of public health insurance in the Czech Republic or in the country of its registered office;
- d) has no outstanding arrears in respect of payments and penalties of social security contributions and contribution to the national employment policy in the Czech Republic or in the country of its registered office;
- e) Is not in liquidation, has not been declared insolvent, in respect of it the enforced administration (receivership) has not been imposed under another legal regulation nor it is in a similar situation pursuant to the law of the country of its registered office

If the supplier is legal entity, the condition according to letter a) must be fulfilled by the legal entity itself and also by every member of its statutory body. If legal entity is a member of the statutory body of the supplier, the condition according to letter a) must be fulfilled by: i) the legal entity; ii) every member of the statutory body of the legal entity; and iii) the person representing the legal entity in statutory body of the supplier.

If the participant in the procurement procedure is a branch of a business of: i) Foreign legal entity: the condition according to letter a) must be fulfilled by the foreign legal entity and by the manager of the relevant company branch; ii) Czech legal entity: the condition according to letter a) must be fulfilled by persons/entities specified in paragraph above and by the manager of the relevant company branch.

The supplier proves the fulfilment of the basic qualification conditions in relation to the Czech Republic by submitting the documents according to § 75 clause 1 PPA, which include:

- a) record from the Criminal Register as per § 74 clause 1 letter a) PPA;
- b) confirmation of the competent tax authority in relation to § 74 clause 1 letter b) PPA;
- c) statutory declaration in writing in relation to excise tax as per § 74 clause 1 letter b) PPA;
- d) statutory declaration regarding excise duty in writing in relation to § 74 clause 1 letter b) PPA;
- e) confirmation of the respective regional social security office in relation to § 74 clause 1 letter d) PPA; and
- f) a copy of an entry in the Commercial Register, or a statutory declaration in writing in the event that the participant is not incorporated in the Commercial Register, in relation to § 74 clause 1 letter e) PPA.

#### 4.2. Professional eligibility according to § 77 PPA:

The bidders shall prove the professional eligibility in relation to the Czech Republic according to § 77 clause 1 PPA by submitting a copy of the **record from the Commercial Register** or similar registry, if registration is required by another legal regulation; the record must prove the fulfilment of the required eligibility criterion at the latest 3 months before the date of the bid submission.

#### 4.3. Technical qualification according to § 79 PPA:

Technical qualification is fulfilled by the bidder who:

4.3.1. has provided at least **one significant supply in last three years** before the tender commencement. The Contracting Authority considers a significant supply to be a supply with the subject matter being the supply of a device similar to the required Distillation Apparatus for continual distillation at minimum value 2 million CZK excluding VAT. As a similar device for the purposes of this public tender is considered a technological device with own control system designed for chemical process testing.

4.3.2. has available a **servicing team, with at least one member**, who:

- Is authorized to work on electrical devices up to 400 V under Regulation No. 50/1978 Coll. on professional eligibility in electrical technology, as amended, at least at level 'Workers for independent activity' as per § 6 of the Regulation or similar qualification comparable within EU;
- Has at minimum 1 year of practise in servicing activity for the defined type of device;
- Is authorized to perform servicing activities of the machine type corresponding to the required device;
- Is able to communicate in Czech, Slovak, or English language.

The participant must prove **the fulfilment of technical qualification according to point 4.3.1.** by submitting the list of significant supplies (the sample forms annex no. 4 of this tender documentation). The correctness will be confirmed by a person authorised to act on behalf of the bidder.

The equivalent record to prove the technical qualification as per point 4.3.1. can be submitted according to § 79 clause 5 PPA, particularly a contract with the client and a record on completing the fulfilment by the supplier.

The participant must prove **the fulfilment of technical qualification according to point 4.3.2.** by submitting the list of persons responsible for providing the respective activities (the sample forms annex no. 4 of this tender documentation). The correctness will be confirmed by a person authorised to act on behalf of the bidder.

#### **4.4. Alternative methods for proving qualification**

As per § 53 clause 4 ZZVZ the Supplier is entitled to substitute the qualification documents in the tender by statutory declaration.

The general and professional qualification can also be proven according to § 226 PPA and by submitting the excerpt from the list of qualified suppliers not older than 3 months.

The Supplier is also authorized to prove the fulfilment of the qualification by means of certificate issued within the system of certified suppliers as per and under the conditions defined in § 233 and as per PPA. The certificate can prove the qualification fulfilment within the scope of defined data.

#### **4.5. Submitting the original records**

As per § 53 clause 4 PPA, during the tender proceeding, the Contracting Authority may request the submission of the original copies or officially verified copies of the qualification documents.

The selected bidder, prior to concluding the contract upon request of the Contracting Authority, must submit the originals or officially verified copies of records proving the fulfilment of the qualification, according to § 86 clause 3 PPA, within the scope the documents were not provided by the bidder within its bid.

#### **4.6. Power of Attorney**

If the bidder provides the power of attorney to a proxy for the signature of the bid, the signature of the contract draft for the public contract fulfilment, and signature of other bid parts of the bidder, the bid must include the power of attorney authorizing the proxy to perform such tasks, in original or in officially verified copy.

#### **4.7. Changes in qualification**

In the case of changes in the qualification by the bidder, it will be proceeded according to § 88 PPA.

#### **4.8. Proving of qualification fulfilment received abroad**

In case the qualification was received abroad, it is proved by the records issued according to the legal regulations of the country where it was received within the scope required by the Contracting Authority. If a certain document is not issued accordingly with the legal order applicable in the country of registered office, place of business or domicile of foreign supplier, foreign supplier is obligated to demonstrate satisfaction of such part of qualification by statutory declaration. If the obligation to be proved within the qualification is not set forth in the country of the registered office, business location of foreign supplier, it will be stated by the statutory declaration.

The suppliers shall attach the translation to Czech or English language of the documents written in foreign language proving the qualification requirement. The documents in Slovakian language do not require translation.

#### **4.9. Qualification proving by means of other persons**

The bidder can prove a specific part of technical qualification or professional eligibility (with the exception of criterion according to § 77 clause 1 PPA) by other persons. In such case, the bidder is obliged to submit the following documents to public Contracting Authority:

- a) documents proving the fulfilment of the professional qualification according to § 77 par. 1 PPA by another person;
- b) documents proving the fulfilment of the missing part of the qualification by another person;
- c) records on the fulfilment of general eligibility to § 74 PPA by another person; and
- d) an obligation in writing from another person to provide performance intended for the fulfilment of the public contract, or to provide items or rights the bidder will be authorised to dispose with within the public contract performance, at least to the extent to which another person has demonstrated the qualification fulfilment for the bidder.

The requirements according to letter d) is considered fulfilled if the content of the obligation in writing from another person is joint and several liability for the fulfilment of the public contract together with the bidder.

#### **4.10. Joint bid**

If the subject matter of the public contract is to be performed jointly by several suppliers who, to this purpose, submit or intend to submit a common bid, each of the suppliers is obliged to prove fulfilment of general qualification pursuant to clause 4.1. hereof and professional qualification as per clause 4.2 hereof within full scope. The remaining qualification shall be proved jointly by the suppliers.

If the subject matter of the public contract is to be performed jointly by several bidders, these are obliged to submit to the Contracting Authority, along with the documents demonstrating the fulfilment of the qualification prerequisites, a contract in writing containing the obligation that all these bidders will be jointly and severally obliged to the Contracting Authority and third parties from any legal relationships (rights and obligations), arising from the public contract, throughout the performance of the public contract, even throughout the period of existence of other obligations, resulting from the public contract.

#### **4.11. Other qualification requirements**

In all other matters the rights and obligations of the bidders as regards to proving the fulfilment of qualification requirements are subject to the respective provisions of PPA.

### **5. Brief description of the contract, obligations, and task of the supplier (bidder)**

The subject matter of the public procurement performance is:

- the supply of the Distillation apparatus for continual distillation including all parts and other components, their installation, commissioning, and operator training, all according to the minimum technical specification defined in Annex no. 1 of this tender documentation (hereinafter referred to as the ‘**Supply**’).
- out-of-warranty service of the Supply subject matter provided solely upon explicit request of the client (hereinafter referred to as ‘**Servicing activity**’).

#### **5.1. Detailed specification of the Supply**

Integral part of the Supply includes particularly:

- Detailed manual for the machine operation in Czech or English language.
- Respective certificates with the authorisation to use the machine in the Czech Republic, i.e. common attests issued by the respective test laboratory in some of the EU country. The documents must be submitted in Czech or English language.
- Training of the operators in Czech or English language for at least 2 working day, within 14 calendar days after installation at the latest. The operators are the employees of the Contracting Authority, at least 2 persons.
- The installation shall be performed at the Contracting Authority’s address no. 2828 at address Chempark, Záluží 1, Litvínov
- 24-month warranty shall be provided for the Supply subject matter from the bidder
- In case of the machine repair in the warranty period, the warranty period extends for the repair duration period, i.e. the period from the defect reporting to its removal. If the warranty repair lasts longer than 3 months or the total period of the machine repairs in one year is longer than 3 months, the client may require the supplier to supply a new device, its parts or the defective unit.
- Warranty of the bidder for the provision of spare parts and consumption material shall be provided for 6 years from the first machine installation.
- Free consulting on telephone during working hours.
- The obligation of the bidder to provide out-of-warranty service under the conditions defined by the contract lasting min. 6 years.

#### **5.2. Detailed specification of the servicing activity**

Servicing activity not included in the subject of the Supply as per article 5.1 of this tender documentation shall be based particularly on the device adjustments which is



a subject matter of the Supply and on the removal of the device defects other than covered by the warranty.

The Servicing activity shall be provided ad hoc, solely based on explicit request of the Contracting Authority, at least for 6 years from the delivery of the Supply subject matter

### **5.3. Further information on the tendering proceedings**

**The fulfilment of the public contract as per the above definitions is financed from the public sources ('Operation Program Research, Development, and Education' of the Ministry of Education, Youth and Sports of the Czech Republic, and also 'Institutional Support', funding projects with the support of the Ministry of Industry and Trade of the Czech Republic).**

During the public contract fulfilment, continual communication is assumed between the bidder and the Contracting Authority, including the performance of partial tasks to provide due supplies and services pursuant to the instructions of the Contracting Authority.

Commercial terms of the public contract implementation are defined in the binding contract sample forming a part of this tender documentation as annex no. 2.

### **5.4. Inspection of place of performance**

The Contracting Authority has organised a joint inspection in the public contract fulfilment location **on 1. 6. 2018 from 10:00 o'clock**. One representative is entitled to participate in the inspection for one supplier. **The bidder shall report the participation to the Contracting Authority at least one working day in advance**, to e-mail address [veronika.vavrouskova@unicre.cz](mailto:veronika.vavrouskova@unicre.cz) and a copy to [ladislav.kudrlicka@unicre.cz](mailto:ladislav.kudrlicka@unicre.cz). All bidders shall arrive for the inspection on the designated day to the main reception desk of Unipetrol RPA, s.r.o. at address Záluží 1, 436 70 Litvínov, at 9:40. **The bidders must have a valid ID card to enter the Chempark premises. Otherwise the entry to the premises will be prohibited.**

Upon concluding the contract, the supplier shall notify the Contracting Authority in writing as regards the cooperation required from the Contracting Authority related to the Supply at least 60 days before the Supply deadline. For this purpose, the Supplier will be obliged to inspect the fulfilment location. The inspection deadline shall be defined upon agreement of both parties.

## **6. Place and Time of the fulfilment**

**Time of fulfilment:**

- the supply, installation, and commissioning of the Distillation apparatus for continual distillation including all parts and other components, their installation, commissioning, all according to the minimum technical specification defined in Annex no. 1 of this tender documentation, including the operator training within the required scope immediately after the installation, must be fulfilled within 150 calendar days from the contract conclusion.
- The operator's training in Czech or English language for at least 2 working day, must be fulfilled within 14 calendar days after installation at the latest. The operators are the employees of the Contracting Authority, at least 2 persons.
- The servicing activity shall be provided based on explicit notice of the Contracting Authority, which the Contracting Authority may request at least for 6 years from accepting the Supply subject matter.

**Place of fulfilment:** Building of the Contracting Authority at address Chempark, Záluží 1 in Litvínov

## **7. Special conditions for the public contract fulfilment**

The contract will be implemented in enclosed premises of Chempark. The supplier will be obliged to respect the rules issued by the premises manager UNIPETROL RPA s.r.o., CRN 275 97 075, with head office in Litvínov - Záluží 1, Post Code 436 70 for the activities of supply companies – see Annexes no. 6 and 7 of this tender documentation (annexes no. 3 and 4 of the binding template of the contract).

The supplier is therefore obliged to agree the conditions for the entry to the premises with the premises manager.

**The bidder is obliged to read in detail all the these rules.**

## **8. Additional conditions of the tender proceedings**

### **8.1. The provision of tender documentation**

Tender documentation forming a part of this document with all annexes will be accessible to public on the profile of the Contracting Authority <http://www.unicre.cz/verejne-zakazky>.

### **8.2. Explanation to the tender documentation**

In compliance with § 98 PPA, the suppliers can request the explanation of tender documentation. Such written request must be delivered to the Contracting Authority within the deadline defined in § 98 clause 3 PPA at the latest. The Contracting Authority shall publish the explanation of the tender documentation on the Contracting Authority's profile within 3 working days after supplier's request delivery at the latest. The Contracting Authority can explain the tender documentation without a prior request.

### **8.3. Bid price processing**

The Supplier shall process separate price bid for the Supply and the Servicing activity.

#### **8.3.1. Bid price for the Supply**

The supplier will process the bid price by filling it in by completing the article VII. 1 of the contract draft.

The bid price excluding VAT is binding for the whole period of the contract fulfilment and for all consideration provided within the Supply according to the contract. The bid price for the Supply excluding VAT covers all contractual obligations and all matters and items required for due fulfilment of the respective obligations according to the contract. The bid price of the Supply with VAT can be increased solely in relation to the legal regulations on the VAT rate, by the maximum amount corresponding to the legislation change.

The Contracting Authority reserves the right to evaluate the bid price in relation to the subject matter of the contract in details of the bid price for the Supply and proceed according to § 113 PPA.

#### **8.3.2. Bid price for the Servicing activities**

The bidder is obliged to state an unified hourly rate for the Servicing activities by filling it to article VII. 3 of the contract draft.

Unified hourly rate excluding VAT must include all costs occurred in relation to the intervention of the bidder (including the costs for the transport to the servicing location, work of persons in any position). The Supplier has the right to charge the servicing intervention from the moment, when the servicing technician arrives to the servicing location.

Unified hourly rate excluding VAT covers all contractual obligations and all matters and items required for appropriate provision of Servicing activity according to the contract. Unified hourly price with VAT can be increased solely in relation to the legal regulations on the VAT rate, by the maximum amount corresponding to the legislation change.

Unified hourly rate does not include only the costs for the acquisition of potential spare or additional parts required for the performance of the servicing intervention.

The remuneration for the provision of the Servicing activity shall be paid according to the hours spent performing the Servicing activity in the servicing location and within the scope of pre-agreed costs for spare and additional parts required for the servicing interventions.

The Contracting Authority reserves the right to evaluate the bid price in relation to the subject matter of the contract in details of the bid price for the Servicing activity and proceed according to § 113 PPA.

#### 8.4. Business terms and the contract template

The business terms are specified in the binding contract draft that forms Annex No. 2 to the present tender documentation.

The draft signed by the person acting on behalf of the bidder shall form a part of the participant's bid. The contract draft defined by the Contracting Authority is binding. The sample contract must not be changed by the bidder, amended or otherwise modified. The bidder shall fill solely the required data identified in the contract for this purpose. Data completed by the bidder in the contract draft must be completed in compliance with the bid. The bidder is also entitled to adjust the identification of the supplier's personnel, in case of filing joint offer.

The bidders must submit all annexes to the completed and duly signed contract draft, as follows:

– **Annex no. 1 – Documentation of the supply / Catalogue Sheets of the Supply**

The bidder must add the specification of the Distillation apparatus for continual distillation that is subject matter of the Supply. The fulfilment of all minimum technical requirements for the machine defined in annex no. 1 of tender documentation, and also fulfilment of all requirements for the control and regulation system and geometry of the apparatus specified in annex no. 1 of the tender documentation must be clear from this specification. Annex no.1 of this tender documentation completed with the statement of the bidder that individual requirements of the Contracting Authority are fulfilled, including information submitted within the bid of the winning participant shall form a part of the contract with the supplier.

– **Annex No. 2 – Description of the servicing activities provided**

The bidder shall use a binding form for the description of the servicing activity provision which forms annex no. 5 of this tender documentation. The Contracting Authority emphasizes that the Description of the servicing activity provision must fully respect all relevant conditions for the fulfilment defined in the contract draft, and the data completed in the contract draft by the participant. Discrepancy of annex no. 2 of the contract and the contract draft text shall constitute a reason for the bid exclusion and excluding the bidder from the tender proceedings. For avoidance of any doubts, the Contracting Authority states that the annex to the contract must not comprise another contract draft, or contain any additional payments charged by the supplier to the Contracting Authority for the performance of servicing activities.

The Contracting Authority emphasizes that the contract with the selected bidder will be concluded in Czech and English languages, in case of any discrepancies, the Czech version

shall prevail. The bidder will submit the contract as a part of its bid in the language version at its own discretion.

#### **8.5. Bid variants**

The Contracting Authority does not allow any bid variants.

#### **8.6. Restriction during the submission of the bids**

Every bidder can only submit one bid.

No employee of the Contracting Authority may participate in the bid processing.

In case of violation of the defined principles, the Contracting Authority will exclude all bids submitted in this way and then all such bidders.

#### **8.7. Tender term:**

Tender term, i.e. the deadline when the bidder is bound with its bid, commences at end of the term for the bid submission, and it lasts for 60 days.

#### **8.8. Sub-delivery**

The bidder must define the parts of the public contract fulfilment which it intends to assign to subcontractors in the bid and state the identification data of every subcontractor. The contracts, concluded between the bidder and the subcontractor, are to be submitted by the bidder within the proving of the qualification fulfilment solely if it proves the qualification fulfilment within the missing scope by means of subcontractor. Other conditions in relation to the subcontracts are defined in the contract template.

#### **8.9. Costs of the bidder**

The Contracting Authority does not confer the bidder's right for compensation of expenses incurred with the participation in the tender proceeding, even in case of the termination of the tender proceedings. Concurrently, the Contracting Authority will not require the compensation of costs for the implementation of the tender proceedings from the bidder, even in the form of payment for real occurred costs or in the form of payments for the bidder's participation in the tender proceedings.

### **9. Requirements for the bid processing**

#### **9.1. Envelope with the bidder's bid**

The bidder will submit the bid in non-transparent closed intact envelope with marked: **'Continual distillation'** with the note **'DO NOT OPEN'**, **name of the bidder and address of the bidder for delivery**. The envelope and another package will be adequately secured from handling (the Contracting Authority recommends to seal the envelope edges and stamp or otherwise mark with the identification data of the bidder).

The Contracting Authority has requested the bidders to submit the bid in original and also in one printed copy and in electronic version on CD - ROM for faster and more continual process of the tender proceedings.

The CD shall contain completely processed bid of the bidder including all annexes in electronic format. Signed documents and their scan, i.e. after the signature of person authorised. Electronic copy of the contract from the offer in format .doc(x). The CD shall be secured from rewriting. The Contracting Authority will appreciate if the data on CD are organised in independent directories 'Qualification' and 'Bid'.

## 9.2. Bid content

The bid must contain:

a) **Title page**

The title page with the name of the public contract, marking the 'original' / 'copy', identification of the Contracting Authority, name/company of the bidder, the content of the bid, and the signature of the bidder or a person authorised to act on behalf of the bidder.

b) **Identification of the bidder**

Document containing the basic data of the bidder. Recommended form of this document forms an Annex no. 3 hereof.

c) **Power of attorney**

The bidder submits the power of attorney solely in case that any document or record within the bid contains a signature of a person representing the bidder or another person based on power of attorney.

d) **Documents to prove the compliance with eligibility/ qualification requirements**

All documents required to prove the fulfilment of the eligibility/ qualification of the supplier within the scope required by the Contracting Authority within this tender documentation.

e) **Documents for the subcontractors used by the bidder to prove the qualification fulfilment**

If the bidder proves the fulfilment of the qualification prerequisites part by means of the subcontractor/s, it must provide the documents in the bid as per § 4.8 hereof

f) **Delivery description**

The bidders will define the subject matter of the supply in such way it is clear it fulfils the minimum technical requirements defined in point 5.1 respectively in annex no. 1 hereof, and the defined requirements are considered minimum, and must be fulfilled at least at the defined level. The bidder in the form defined in

Annex no. 1 column 'Statement of the bidder' **defines explicitly for every requirement that offered machine is compliant, eventually defines the method or states the value.** At the same time, the bidder submits the technical specification (or reference to the specification) for the offered machine including all parts and accessories or other components defined in annex no. 1 of this tender documentation, which enables the Contracting Authority to verify the fulfilment of the defined minimum requirements. The bidder shall define further technical specifications of the device at its sole discretion. Such completed *annex no. 1* shall form a part of the contract with the supplier.

g) **Draft contract**

The contract draft compliant with the respective binding contract draft as per this tender documentation completed with relevant data on indicated places. The contract draft **must be signed by the bidder or a person authorised to represent the bidder. All required annexes must be completed and attached to the contract draft.**

h) **Data on sub-deliveries**

The bidder submits the data only in case it plans to assign some parts of the fulfilment to the subcontractor. The list will include the parts of public contract fulfilment which the bidder plans to assign to specified subcontractors. The record must contain the identification data of all subcontractors and relevant definition of the subcontractor's fulfilment.

### 9.3. Language of the bid

All documents in the envelope with the bid of the bidder must be in Czech, English, or Slovak language (or foreign language with officially verified translation to Czech or English). Slovakian language is permitted by the Contracting Authority for the records submitted to prove the qualification. Latin language is permitted for the records on education. Potentially attached brochures, application sheets, complementary information on the offered devices, etc., can be in any language.

## 10. Criteria and method for the bids evaluation

The general evaluation criterion for assigning the public contract is the **economical effectiveness**, proven by partial evaluation criteria:

No.	Partial evaluation criterion	Weight
1.	Bid price for the Supply	80 %
2.	Out-of-warranty service	20 %

The selection of the most suitable bid will be performed by the evaluation committee appointed by the Contracting Authority.

### 10.1. Partial evaluation criterion I - Bid price for the Supply

The subject matter of the partial criterion is the Bid price of the Supply excl. VAT processed in compliance with article 8.3.1. of this tender documentation.

The lowest total Bid price for the Supply excluding VAT represents a better bid.

Based on the comparison of the Bid prices for the supply excluding VAT from individual bidders, the bidder with the lowest bid price of the supply excluding VAT shall receive 100 points, whereas other bids shall receive the score corresponding to the ratio of the lowest Bid price for the Supply excluding VAT and the Evaluated bid price for the Supply excluding VAT multiplied by 100 and rounded to two decimal points.

### 10.2. Partial assessment criterion II – Out-of-warranty service

This partial criteria will be assessed by the following sub-criteria:

No.	Sub-criterion	Weight
1.	Reaction speed to the reported defect in the delivery location	50 %
2.	Bid price for 1 hour of Servicing activities	50 %

#### 10.2.1. Reaction speed to the reported defect in the delivery location

Subject matter of this sub-criterion is the reaction period filled by the bidder in the art. V clause 3 of the contract draft. The reaction period shall be filled by the bidder in the contract in full hours, otherwise the Contracting Authority shall round the offered reaction period to full hours up. The reaction period must not exceed 120 hours.

If the reaction period is stated by the bidder from 0 hours to 24 hours (inclusive), the bid shall receive 100 b within this sub-criterion.

If the reaction period is stated by the bidder from 25 hours to 96 hours (inclusive), the bid shall receive 50 b within this sub-criterion.

If the reaction period is stated by the bidder from 97 hours to 120 hours (inclusive), the bid shall receive 0 b within this sub-criterion.

If the reaction period exceeds 120 hours, the bidder's offer will be excluded and the bidder will be eliminated from the tender proceedings.

#### 10.2.2. Bid price for 1 hour of Servicing activities

The subject matter of the sub-criterion is the Servicing activity processed in compliance with article 8.3.2. hereof.



Lower hourly rate for the Servicing activity excluding VAT represents a better bid.

Based on the comparison of the offered hourly rates for the Servicing activity excluding VAT from individual bidders, the bidder with the lowest hourly rates for the Servicing activity excluding VAT shall receive 100 points, whereas other bids shall receive the score corresponding to the ratio of the lowest hourly rates for the Servicing activity excluding VAT and the evaluated hourly rates for the Servicing activity excluding VAT multiplied by 100 and rounded to two decimal places.

### **10.2.3. Evaluation within partial assessment criterion II – Out-of-warranty service**

The points received in the respective sub-criterion will be multiplied by the significance level (weight). The sum of points adjusted in this manner is the number of points received within partial assessment criterion II – Out-of-warranty service.

### **10.3. Final assessment**

The points received in the respective partial assessment criterion will be multiplied by the significance level (weight). The sum of points adjusted in this manner is for both partial criteria defines the position of the bidder in the total evaluation of the bid. The winning bidder shall be the bidder with the highest score.

## **11. Rights of the Contracting Authority**

The bidders do not have the right for compensation of expenses associated with the participation in the tender proceeding.

The Contracting Authority reserves the right to:

- verify the information stated by the bidder in the bid prior to the decision on the selection of the winning bid;
- not return the submitted bid.

**As per § 53 clause 5 PPA, Contracting Authority reserves the right to notify of the elimination of the bidder and/or the selection of the supplier by publishing on the Contracting Authority's profile. In such case, the notifications are considered delivered to all bidders at the moment of their publishing.**

## **12. Opening the bids**

The bids shall be opened pursuant to § 110 PPA. The envelopes opening with the bid will take place on **27. 6. 2018 FROM 11:00 o'clock** (immediately after the deadline for the bid submission) in the head office of the Contracting Authority. Only 1 representative of the bidder submitting the bid before the end of the term for the bid submitting can be present during the opening of envelopes with the bids. In case of foreign bidder, the Contracting Authority admits the presence of an interpreter. The bidder will prove himself with a full power of attorney signed by the person authorised

to act on behalf of the bidder if it is not the statutory body. If it is the statutory body, it will provide the document proving its position (for example the extract from commercial register).

### 13. Annexes

Annex No.1 – Technical Specification

Annex No. 2 - Binding contract draft

Annex no. 3 – Identification of the bidder

Annex No.4 – Declaration for technical qualification prerequisites

Annex No. 5 – Description of the Servicing activities provided

Annex no. 6 – Conditions for the entry and movement in Chempark Záluží

Annex no. 7 – Services provided by the manager of Chempark Záluží

In Litvínov on 14.5.2018

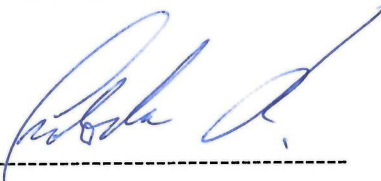

Ing. František Svoboda  
*Chairman of the Board of Directors*



doc. Ing. Jaromír Lederer, CSc.  
*Vice-chairman of Board of Directors*

Unipetrol výzkumně vzdělávací centrum, a.s.  
Revoluční 1521/4, 200 01 Ústí nad Labem  
IČO: 622 43 136 DiČ: CZ02243136 ⑦

**Annex No. 1 of the Tender documentation for below-threshold public contract  
'Continual Distillation'**

The continual distillation apparatus will be used for the distillation separation of higher amount of substance mixtures, materials for the research experiments and products from the operation of research units. It will also be used for the preparation of marketing samples of new products.

The distillation shall apply mostly to hydrocarbon mixtures within wide range of carbon chain length, from pentane fractions to petroleum fractions, medium distillates, aromatics (including multi-nuclear – e.g. naphthalene and its alkyl derivatives), to wax fractions from the Fischer-Tropsch synthesis. Also distilled will be the mixtures of oxygenic substances from biomass processing with the content of alcohols, esters, ethers, aldehydes, ketones, phenols, and fatty acids.

**1. Minimum technical requirements:**

<b>Requirements</b>	<b>Statement of the bidder (the bidder shall define the specifications fulfilled by the offered equipment)</b>
<b>Instrument</b>	
A column with minimum internal diameter of 50 mm consisting of three sections connected by means of a dismountable method, with feed-point locations (2 totally) between adjacent sections	
The interior of the column is filled with distillation packing, which can be removed without the destruction of the column or any of its parts, selected to ensure the total column efficiency reaching at least 50 theoretical stages under optimum operation conditions, tested on hydrocarbon mixtures.	
The possibility to operate at atmospheric and reduced pressure as well	
Lower limit of operating pressure of 2,0 mbar	
Upper limit of the column operating temperature at least 250 °C	
The construction of feed-point locations assuring the liquid input in the column axis	
The construction of distillation column with a mantle providing adiabatic mode, i.e. with the lowest possible heat loss through the column wall, and with the heat loss compensation by additional electrical heating with independent regulation for each column section	
Construction material of all parts in direct contact with the processed media should be resistant to hydrocarbons, organic acids, and aldehydes.	
Device for vacuum generation and control	
Feed pump for dosing liquid within the range 0,5 – 2 l/h	
Feed tank with minimum volume of 30 l, operating at the pressure range 100 - 110 kPa, with tempering option within the range 0 to 150 °C (including the delivery of external device-thermostat for tempering and with the option of gas space inertization	
The feed tubing enabling optional use of both feed-point locations with the possibility to heat the tubes up to 150 °C	
Feed pre-heater (as close to the column entry as possible) – with the outlet temperature of 150 °C for the feed value of 2l/h (calculated for medium oil distillate) <sup>i</sup>	
Removable distillation head and re-boiler	

Distillation head, tempered by cooling (heating) liquid within the temperature range 0 °C to 100 °C (including the delivery of an external device-thermostat for tempering)	
The construction enabling the setting and control of the reflux to distillate ratio within the range 0 to 10:1	
Possibility of tempering of the gas tube-lines of the distillation head and all distillate withdrawing lines (up to the apparatus border) within temperature range 0°C to 100 °C. In optimum, the system connectable to the thermostat providing cooling (heating) of the distillation head.	
Electrically heated re-boiler with the possibility of distillation residue withdrawing from the re-boiler bottom	
Re-boiler volume within 2-4 l	
Re-boiler operating temperature up to 300°C.	
The system of continual withdrawing of distillation residue operating within the whole range of the column operating pressures with adjustable flow within range from 0,1 to 1,5 l/h, with the cooler for pre-cooling the distillation residue from maximum boiler temperature to 50 to 100 °C.	
<b>Measurement and control system</b>	
Monitoring and electronic archiving of temperature values on the distillation head, in the re-boiler, and at the feed points	
Measuring control, and archiving of measured pressure values on the column head	
Measuring, archiving of the pressure difference on the column	
Electronic regulation of the re-boiler power input	
Electronic regulation of the column power input - independent regulation of each section as well as temperature measuring in each section	
Column reflux control	
Setting all controlled values by means of PC	
The control and measuring of the feed and the re-boiler residue flow values - archiving the measured values by means of PC	
The collection and archiving of all measured values by means of PC	
The possibility to export of the measured values and stored data in a format readable by some Microsoft Office program – ideally Excel	
The control PC device should be included in the delivery.	
<b>Apparatus geometry</b>	
Maximum height: 5m	
Maximum width: 2.5 m	
Maximum depth: 0.7 m	

2. **The delivery includes the below items:**

- The device installation including all related activities (packaging, transport, disposal of waste),

- Documentation including manual in Czech, Slovak or English language,
- Professional team training for the machine operation (min. 2 employees of the Contracting Authority) at minimum length of 2 working days,
- The warranty period for at least 24 months
- The device will be installed in cubicle 1.19 and connected to cable outlet C.3 (see schemas below).

### Cubicle description 1.19

Continual distillation will be located in the premises of Chempark, construction 2828, cubicle no. 1.19, with normal dust environment. Basic dimensions of the cubicle - height 5 m x width 4,8 m x depth 3 m. The western side of the cubicle is fitted with socket distribution at height 1 m approx 0,2 m from the sides of northern and southern wall. The northern side, approximately in the wall centre includes three cable outlet (C3, C4, C5) CYKY – J 5x6 with total protection 25A, (LPN – 25C – 3N). Continual distillation is considered for supply cable outlet „C3“. Lighting (lamp units) is located in the western side at approx height 2 m and approx at 5 m. The corner of the northern and western side includes two gas detection sensors at approx height 2 m. The eastern side includes the heating radiator, emergency exhaust - (tube with diameter 0,3 m up to approx height 3,5 m from the floor). The windows are in the southern part, the lower window edge is approx 3,8 m from the floor, and the width of one window is 1,5 m. The cubicle includes two windows with the same dimension. The floor is made of concrete finish and cambered to the drain channel.

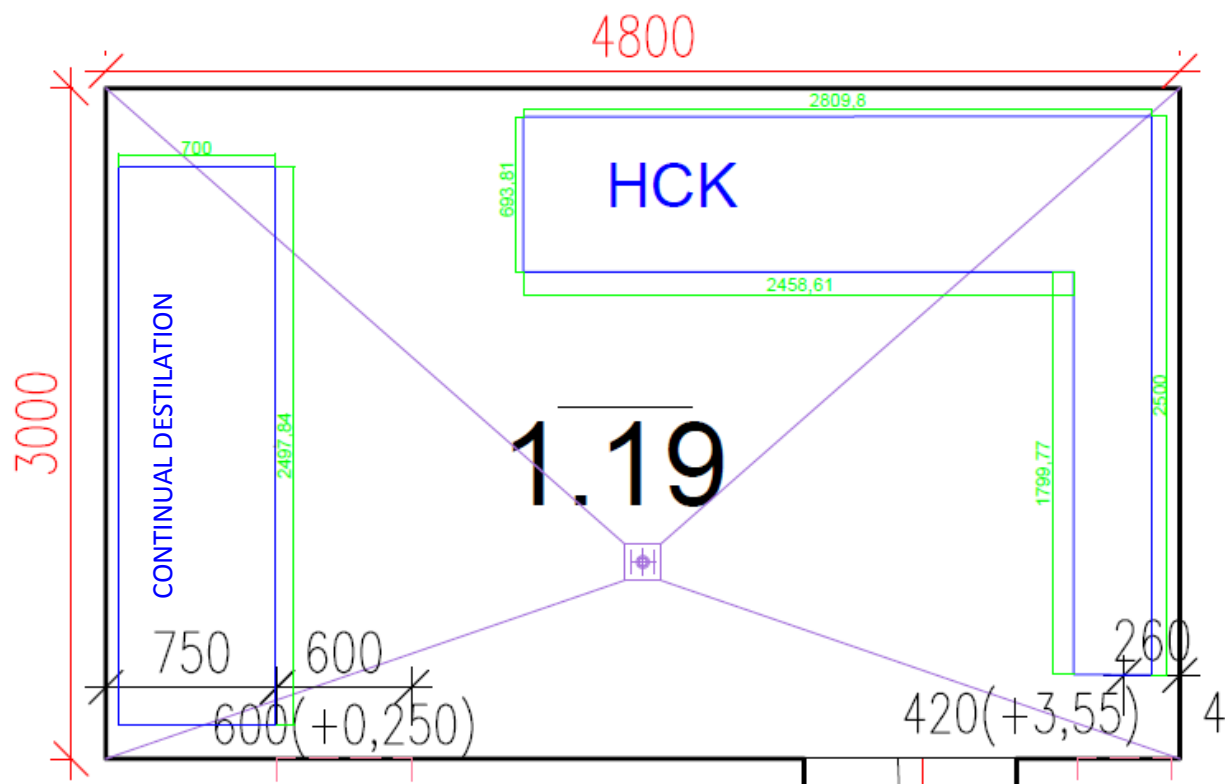

<sup>i</sup> The same thermostat can be used for tempering the whole spray route

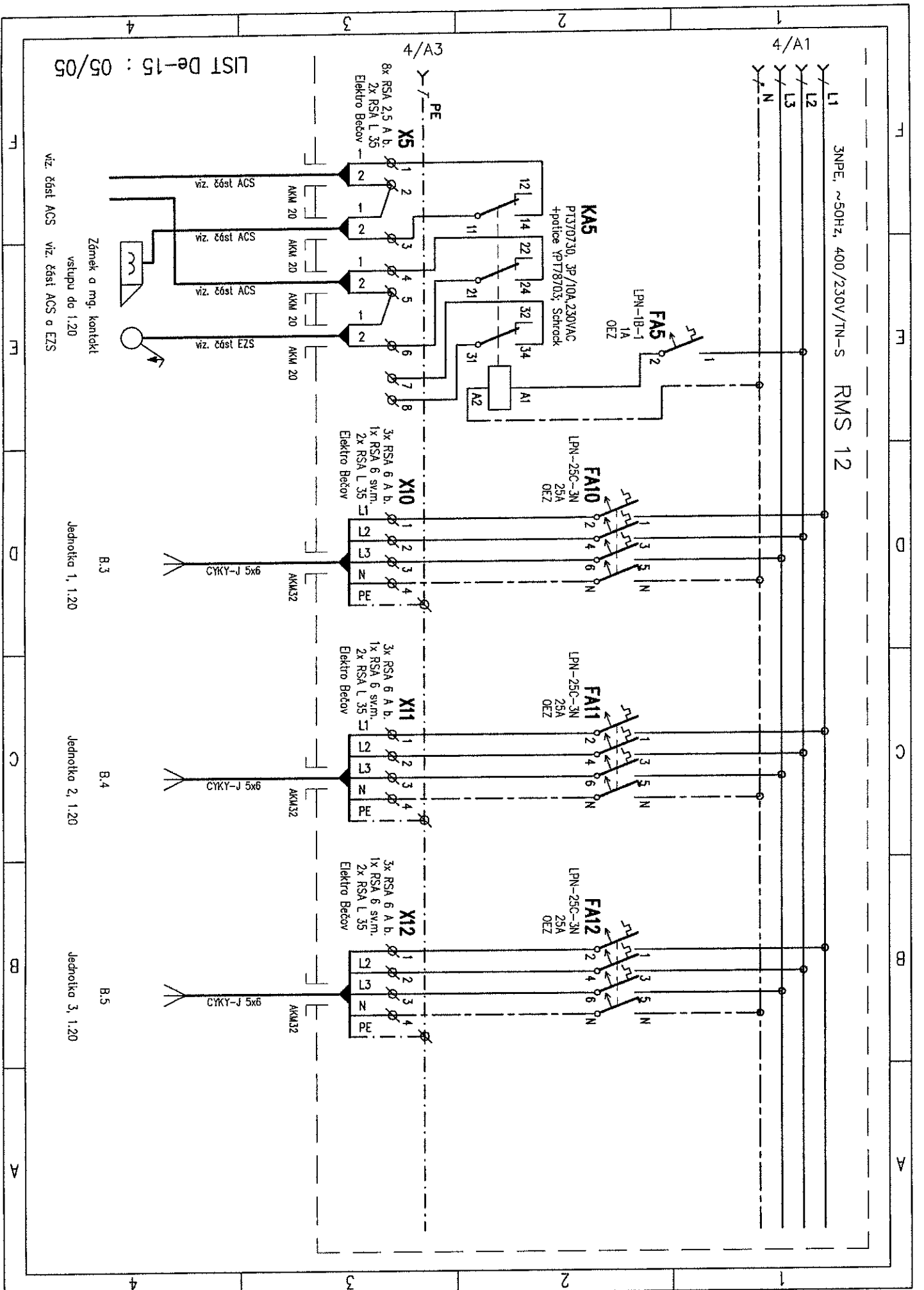

Annex No. 2 of Tender documentation for the public contract ‘Continual Distillation’

### Contract on supply

Concluded as per § 1746 clause 2 et seq. Act No. 89/2012 Coll., Civil Code, as amended

#### Contracting Parties:

**Business name:** Unipetrol Centre for Research and Education, a.s.  
**Head office:** Revoluční 84, 400 01 Ústí nad Labem  
**CRN:** 62243136  
**Tax ID:** CZ62243136  
**Bank details:** Komerční banka Ústí nad Labem  
**Account no.:** 7009-411/0100  
**Record in the Companies Register:** Regional court in Ústí nad Labem, section B, insert 664  
**Represented by:** Ing. František Svoboda, Chairman of the Board  
doc. Ing. Jaromír Lederer, CSc., Vice-Chairman of the Board

**Person authorized to act in technical matters:** Ing. Veronika Vavroušková – Manager of Infrastructure Projects, e-mail: [veronika.vavrouskova@unicre.cz](mailto:veronika.vavrouskova@unicre.cz), tel: 471 122 305  
**Person for implementation:** Ing. Ladislav Kudrlička, Research Employee  
email: [ladislav.kudrlicka@unicre.cz](mailto:ladislav.kudrlicka@unicre.cz), tel: 736 506 280

as one party  
(hereinafter referred to as “**Client**”)

and

**Business name / name** [to be added by the bidder]  
**Identification number/ birth registration no.:** [to be added by the bidder]  
**Head office/ address:** [to be added by the bidder]  
**CRN:** [to be added by the bidder]  
**Tax ID:** [to be added by the bidder]  
**Bank details:** [to be added by the bidder]  
**Account no.:** [to be added by the bidder]  
**Record in the Companies Register:** [to be added by the bidder]  
**Represented by:** [to be added by the bidder]

as another party  
(hereinafter referred to as „**Supplier**“)

based on their true and free will, conclude this

**Contract on supply**  
(hereinafter referred to as „**Contract**“)

## **PREAMBLE**

This contract is concluded for the fulfilment of the overlimit public contract ‘**Continual distillation** (hereinafter referred to as ‘**Public Contract**’).

The Public Contract fulfilment forms a part of the project implementation ‘The Development of Research Infrastructure CATPRO’, implemented within the program ‘Operational Program Research, Development, and Education’ (OP RDE) with financial support from the European Union and state budget of the CR – the operational program is managed by Ministry of Education, Youth, and Sports of the Czech Republic. The fulfilment of the Public Contract shall also be partially financed from the sources of the Ministry of Industry and Trade of the Czech Republic, specifically from Institutional support, potentially from own sources of the Client.

### **I. Subject and Purpose of the Contract**

1. The Supplier hereby undertakes to supply and handover to the Client the **distillation apparatus for continual distillation** with all parts and accessories according to the detailed specification defined in annex no.1 hereof (hereinafter referred to as ‘**Supply subject matter**’), and enable the Client to obtain the ownership title to the Supply subject matter.
2. The Client undertakes to accept the Supply subject matter with all parts and accessories, rights and obligations, and undertakes to pay the Supplier the purchase price as agreed under this Contract.
3. For the minimal period of 6 years after the Contract conclusion, the Supplier further undertakes to perform activities of out-of-warranty service of the Supply subject matter based on explicit requests from the Client which may be based particularly on the adjustment of the Supply subject matter and on the removal of defects of the Supply subject matter which are not covered by the warranty (hereinafter referred to as ‘**Out-of-warranty service**’). The Client undertakes to pay remuneration to the Supplier for the provision of Out-of-warranty service agreed below in the Contract.
4. The purpose of the Contract is the stipulation of rights and obligations of the contracting parties related to the Supply subject matter and the provision of the below defined services required for the project implementation ‘The Development of Research Infrastructure CATPRO’ (see the Preamble hereof).

### **II. Delivery Conditions for the Supply Subject Matter**

1. The supply subject matter will be used by the Client particularly for the distillation division of higher amount of substance mixtures, both materials for the research



experiments and products of operation of research units. It will also be used for the preparation of marketing samples of new products.

2. The delivery of the Supply subject matter includes the machine transport to the performance location, its installation including all related activities (packaging, transport, disposal of waste, etc.), commissioning. The Supply subject matter also includes the provision of free telephone consultations by the Supplier to the Client during working hours.
3. The Supplier is also obliged to train the operators of the Supply subject matter which includes at least 2 employees of the Client, as follows:
  - a. Training in Czech or English language for at least 2 working day, within 14 calendar days after installation at the latest. Training date must be agreed by the Client. The relevant focus of training must be within the scope required by the Client; the training shall include detailed familiarization with the functions and operation of the device, and the provision of information related to the device functions, and answers from the Supplier to the Client's employees.
4. The delivery of the Supply subject matter includes the supply of the below documentation:
  - a. Detailed operating manual for the Supply subject matter, maintenance manual in Czech or English language;
  - b. Warranty sheets, potentially required certificates, Conformity declaration and other materials required for the inspection bodies of the Supply subject matter;
  - c. Respective certificates with the authorisation to use the Supply subject matter in the Czech Republic, i.e. common attests issued by the respective official test laboratory in some of the EU country;

All documents mentioned in points 4. b. and 4. c. and submitted to the Client by the Supplier must be in Czech or English language, or in official translation to Czech or English language.
5. The Client undertakes to provide the Supplier with all cooperation necessary for the fulfilment of the obligations pursuant to this Contract. The Supplier is obliged to inspect performance location under this Contract and notify the Client in writing of the required cooperation at least 60 days before the deadline for the Supply subject matter delivery.
6. The Client is entitled to inform the Supplier about its reservations or detailed instructions for the delivery of the Supply subject matter. The Supplier is obligated to consider and respect them.
7. The Supplier declares that it is fully acquainted also with other terms for the fulfilment of its obligations resulting from this Contract but not defined herein explicitly.
8. In the performance hereof, the Supplier is obliged to proceed with due diligence. The Supplier is obliged to observe the binding legal regulations, directives and other regulations.

### **III. Statement regarding the Supply Subject Matter**

1. The Supplier declares and is responsible to the Client for that on the day of delivery of the Supply subject matter:
  - a. The Client is an exclusive owner of the Supply subject matter;
  - b. The Supply subject matter fulfils all requirements defined by the respective legal regulations and the tender documentation for the Public Contract; particularly fulfils the technical parameters defined in annex no. 1 of the tender documentation for the Public Contract and in annex no. 1 hereof.
  - c. The Supply subject matter is new, unused, undamaged, fully functional, at the highest quality, and with all legal rights required for appropriate and undisturbed handling and usage by the Client including all intellectual property rights;
  - d. The Supply subject matter is not subject to any burdens, pledges, transfer limits, pre-emptive rights, or other restrictions for the benefit of third parties, leases, subleases, rights of use, and other rights of third persons regardless of whether the rights are registered in public registries or not;
  - e. The Supplier is entitled to conclude and fulfil this Contract which is completely and unconditionally binding, and by signing and fulfilling this contract it shall not violate any other contract the Supplier have concluded, or any generally binding legal regulations;
2. The Supplier declares that on the day of concluding the Contract:
  - a. It is not a participant of any court, arbitrator, or administration proceedings which could affect its ability to duly fulfil the obligations resulting hereof, particularly that the assets of the Supplier are not subject to the bankruptcy, settlement, or insolvency proceedings, and there is no execution, and it is not aware of any risks that such court, arbitrator, or administration proceedings could be commenced;
  - b. It is not bankrupt nor it faces bankruptcy;
  - c. It has no debts or due payments which could result in the court right of lien, executor right of lien, or right of lien as per § 170 act no. 280/2009 Coll., Tax Code, or execution affecting the Supply subject matter;
3. Falsity or incompleteness of any declaration of the Supplier defined in article III.1 and/ or III.2 hereof is considered a substantial breach of the Supplier's obligations as per this Contract which entitles the Client to withdraw from the Contract by means of a notification on withdrawal in writing. The Client declares that partial fulfilment has no purpose for the Client. The Client's right to damages is not affected.

#### **IV. Conditions for the provision of Out-of-warranty service**

1. The Client is not obliged to make a request for the fulfilment of any services related to the Out-of-warranty service and the Supplier is not entitled to perform any such service without such request. Details of warranty service and Out-of-warranty service are specified in Annex no. 2 hereof.
2. The request for the provision of services within the Out-of-warranty service shall be sent by the Client to the Supplier to email address [to be completed by the bidder].
3. The Client shall define in the request the description of the services covered by the Out-of-warranty service requested from the Supplier and shall determine an adequate period for their provision.
4. The Supplier is obliged, for the whole period of the Contract duration, to maintain a servicing team corresponding to the bid within the tender procedure for the Public Contract, potentially with the exchange of the servicing team member on condition that the new servicing team member fulfils the requirements defined in the tender documentation for the Public Contract. The Supplier is, upon the request of the Client, obliged to submit the documents proving the required qualification of the new servicing team member, within the deadline defined by the Client and the in form required by the Client.

#### **V. Date and place of performance**

1. The Supplier undertakes to deliver the Supply subject matter to the Client with all parts and accessories, including the installation, commissioning, and the delivery of complete documentation, **within 150 calendar days from concluding the Contract, but no later than 28 February 2019.**
2. The Supplier undertakes to perform the operator training according to article II.3.a) of the Contract at the latest within 14 days from installing the Supply subject matter. The Supplier is obliged to propose to the Client to choose the date for the training from 3 various dates.
3. The Out-of-warranty servicing activity shall be provided based on explicit request of the Client, which the Client may make within at least 6 years from accepting the Supply subject matter. The Supplier undertakes that the servicing technician shall arrive to the location of the servicing intervention at the latest within [to be added by the bidder] hours from receiving the email request from the Client (hereinafter referred to as the "reaction time"). If the request of the Client is sent by an email on the working days from 9 AM to 6 PM, the request is considered delivered on the moment of its sending. In all other cases the request is considered delivered at 9 AM of the following working day after sending. If the end of the reaction time is not on the working day from 9 AM to 6 PM the end of the reaction time shall be considered on the following working day at 9 AM. The deadlines for the removal of defects are subject analogically to the provisions of article IX clause 9 and 10 of this Contract.
4. The performance location of the Contract subject matter, i.e. the location of the supply and installation of the Supply subject matter, and the performance location of

the servicing intervention, is the building of Unipetrol Centre for Research and Education, a.s. on the address Chempark Záluží - Záluží 1, 436 70 Litvínov.

5. The Supplier, for the purposes of the Contract fulfilment, is obliged to arrange the entry to the premises of Chempark Záluží at its own costs, i.e. arrange the adequate authorisation with the premises site manager. For the whole period of Contract fulfilment the Supplier is obliged to observe binding conditions of the entry, drive-in, and movement around the premises of Chempark Záluží, which together form annex no. 3 and 4 of the Contract, or which will be defined by the site manager of Chempark Záluží.

## **VI. Handover and acceptance of the Supply subject matter and transfer of the ownership title**

1. The Supplier is obliged to handover the Supply subject matter to the Client duly and in time, in compliance with the instructions of the Client and this Contract, in quality corresponding to the specification of the Supply subject matter as per this Contract, all its annexes and purpose for which the supply is provided.
2. The particular day of the Supply subject matter handover shall be defined by the Supplier by notifying the Client in writing, by telephone, by fax or by electronic mail at least 15 days before the Supply subject matter handover. Unless agreed otherwise by the contracting parties, the day of the Supply subject matter handover shall be a working day.
3. The Supplier is obliged to deliver the Supply subject matter to the Client together with all accessories, records and documents related to the Supply subject matter.
4. The handover process and acceptance of the Supply subject matter include the installation and commissioning of the Supply subject matter including the prove of the performance parameters of the Supply subject matter, and also the provision of the calibration including the calibration protocol. Before the moment of handover and acceptance of the Supply subject matter, the Supplier must fulfil all its obligations under this Contract in relation to the delivery of the Supply subject matter, except for the operator training within the scope of training according to article II.3.a) of the Contract.
5. The handover and acceptance of the Supply subject matter by the contracting parties is subject to the handover protocol in writing which will, amongst other, contain the explicit confirmation of the Client of the acceptance of the Supply subject matter.
6. At the moment of accepting the Supply subject matter, the Client obtain the ownership titles to the Supply subject matter, and all tangible and intangible outputs directly related to the Supply subject matter.
7. If the Supply subject matter or related services (installation, calibration) indicate any defects or incomplete work (incomplete services related to the supply), the Client is entitled to refuse the acceptance of the Supply subject matter.
8. The damage risk to the Supply subject matter is transferred to the Client on the day of accepting the Supply subject matter by the Client free from defects.

9. Due completion of the operator training within the scope of training as per article II.3.a) of the Contract shall be subject to a protocol made by the contracting parties, where the Client explicitly confirms the service was implemented within the agreed scope, quality, and deadline.
10. Due provision of Out-of-warranty service based on individual request shall also be subject to a protocol made by the contracting parties, where the Client explicitly confirms the service was implemented within the agreed quality and deadline. The contracting parties shall confirm the hours really spent performing the Out-of-warranty service in the servicing location and potentially the costs for the acquisition of spare and additional parts delivered to the Client during the servicing intervention.

### **VII. Contract price for the fulfilment**

1. The total price of the Supply subject matter is [to be added by the bidder] CZK excluding VAT, i.e. [to be added by the bidder] CZK incl. VAT.
2. The total price of the Supply subject matter excluding VAT is binding for the whole period of the Contract fulfilment and for all performances within the supply of the Supply subject matter included under the Contract. The bid price of the Supply subject matter excluding VAT covers all contractual obligations and all matters and items required for due fulfilment of the respective obligations according to the contract (including the related services such as training). The price of the Supply subject matter with VAT may be increased solely in relation to the change of legal regulations for the VAT rate, by the maximum amount corresponding to the legislation change.
3. Price for 1 hour of the Out-of-warranty service is [to be added by the bidder] CZK/hour, excluding VAT, i.e. [to be added by the bidder] CZK/hour with VAT.
4. Price for 1 hour of services provided within the Out-of-warranty service includes all costs occurred in relation to the intervention of the Supplier (including the costs of the transport to the servicing location, work of persons on any position). The Supplier is entitled to charge remuneration for the servicing intervention from the moment of servicing technician arrival to the servicing location. Price for 1 hour of Out-of-warranty service excluding VAT covers all contractual obligations and all matters and items required for due provision of Out-of-warranty service under the Contract. Price for 1 hour of the provision of Out-of-warranty service with VAT may be increased solely in relation to the change of legal regulations for the VAT rate, by the maximum amount corresponding to the legislation change.
5. Price for 1 hour of the provision of Out-of-warranty service does not include costs for the acquisition of eventual spare or additional parts required for the performance of the servicing intervention. The costs must be agreed by the Client in writing in advance.

### **VIII. Payment Terms**

1. The Client will not provide the Supplier with any advance payments.

2. The Supplier shall be entitled to the payment of the total price of the Supply subject matter according to article VII. clause 1 hereof at the moment of the Supply subject matter handover to the Client.
3. The Supplier shall be entitled to the payment of the price for the provision of Out-of-warranty service upon the particular request at the moment the respective service is duly provided to the Client.
4. The total price of the Supply subject matter is due (mature) based on an invoice issued by the Supplier after the entitlement for the total price payment for the Supply subject matter. The price for the provision of Out-of-warranty service upon the particular request is due (valid) based on an invoice issued by the Supplier after the entitlement for the price payment for the Out-of-warranty service upon the particular request.
5. The invoice must contain requirements of tax document according to the respective legal regulations of the Czech Republic, it must be issued in Czech koruna (CZK) and it must be due within thirty (30) days. It must contain:
  - Registration number of the Contract;
  - Identification of banking institution and account no. to which the payment is to be transferred;
  - Public Contract title.
6. An annex to the invoice must include the copy of the handover protocol, whereby the Client confirmed the acceptance of the Supply subject matter. In case of the Out-of-warranty services, the copy of the handover protocol must be attached as an annex according to article VI.10 hereof.
7. If the invoice does not contain the above mentioned requirements, the Client is entitled to return it to the Supplier for correction or completion. In such case the maturity period stops, and new maturity period under this Contract starts anew as of the date of corrected invoice delivery to the Client.

### **IX Liability for Defects**

1. The Supplier undertakes that the Supply subject matter will be of the top quality, i.e. all properties of the Supply subject matter will satisfy the defined requirements, i.e. the utilisation, operation safety, defect-free operation, sustainability, economic operation, the provision of environmental protection etc. These properties will comply with the valid legal regulations in the CR, Czech technical standards accepting the European standards. The Supplier assures the Client that the Supply subject matter is free from any defects.
2. The Contracting parties have agreed that the Supplier will provide a guarantee for the Supply subject matter quality, i.e. The Supplier undertakes and guarantees that for the duration of the contractual warranty period, the Supply subject matter will be eligible for use according to its purpose and it will maintain the agreed properties and quality as per the Contract and its annexes. The Supplier guarantees that the Supply subject

matter will have the properties defined in the technical standards (ČSN) and the regulations relevant for the Supply subject matter completion.

3. The Supply subject matter has defects, i.e. deviations in quality, content, scope or parameters incompliant with the conditions defined in the Contract, technical standards and generally binding regulations, if the Supply subject matter completion does not comply with the requirements defined in the Contract and other documentation related to its completion. The Supplier is responsible for the defects of the Supply subject matter at the time of its handover, and the defects that occurred during the warranty period. During the warranty period, the Supplier is not responsible for the defects that occurred due to incompliance or violation of the submitted regulations for the operation and maintenance by the Client.
4. The contracting parties agree that Supply subject matter is defective if the statements of the Supplier as per article III hereof prove to be untrue or incomplete.
5. The Supplier provides 24 months warranty period for the Supply subject matter including all related services. All these services are provided free of charge by the Supplier for the warranty period duration (hereinafter referred to as "**warranty activities**"). The provision of warranty activities by the Supplier does not affect the right of the Client to the Out-of-warranty services according to article IV. hereof. The warranty period starts on the day the Supply subject matter is handed over and accepted free of defects.
6. The warranty period is extended by the period when the Client cannot use the Supply subject matter due to the defects. In case of the device repair during the warranty period, the warranty period extends by the repair duration period, i.e. the period from the defect reporting to its removal. If the warranty repair lasts longer than 3 months or the total period of the Supply subject matter repairs in one year is longer than 3 months, the Client may require the Supplier to supply a new device, its parts or to replace the defective unit.
7. The Supplier guarantees to the Client and undertakes that the spare parts and consumption material shall be available for at least 6 years from handing over and accepting of the Supply subject matter.
8. The Client will notify the defect by fax, email, by means of data box or mail. The notification of the defect must contain a brief description of the defect, the place, and cause of the defect, and its effects.
9. If a defect of the Supply subject matter that occurred during the warranty period prevents from the use for common purpose, the Supplier is obliged to commence works to remove the defects immediately after the notification in writing from the Client as per article IX.8 hereof. Unless the contracting parties agree otherwise, the Supplier is obliged to remove the defect preventing from the use of the Supply subject matter for common purpose at the latest within 5 working days from delivering the notice of a defect.
10. If a defect of the Supply subject matter that occurred during the warranty period does not prevent from the use for common purpose, the Supplier is obliged to commence works to remove the defects within 5 working days after receiving the notification in writing from the Client as per article IX.8 hereof. The Supplier is obliged to remove

the defect not preventing from the use of the Supply subject matter for common purpose at the latest within 10 working days from delivering the notice of a defect.

11. The contracting parties have agreed that the Client, in case of finding a defect, must notify the Supplier within sixty (60) days from finding the defect. The contracting parties have agreed that all consequences related to late notification of defects according to Act No. 89/2012, Civil Code, may only occur after the agreed period for the notification of the defects.
12. The Client shall enable the Supplier the entry to the premises to remove the defects, including the connection to the utilities. In case of any damage caused during the warranty defect removal, the Supplier is obliged to fully reimburse it, within three days from the damages claim by the Client.
13. The Supplier shall handover the repaired defect to the Supplier including the protocol of handover of repaired defect. The completed repair, within the contractual warranty period, is subject to 24 months warranty provided by the Supplier from its removal and date of handover. It also applies to the spare parts exchanged during the repair works, including the Out-of-warranty service.
14. If the Supplier fails to remove the defect using a defined method within 15 working days from the day of choose of claim by the Client, the Client is entitled to order the defect removal from another supplier. The Supplier is then obliged to pay the factual costs of the defect removal, within 14 days from the cost clearance by the Client. The warranty for quality and the claims from the defect are not affected.
15. In order to eliminate any doubts, it is agreed that the above mentioned does not eliminate the right of the Client to select other rights arising from defective performance than the defect removal by repair. The Client may choose the entitlement from defective performance within thirty (30) days from the defect notification and can change the claim arising from the defective performance according to its consideration until the completion of the claim chosen by the Supplier.
16. If the Purchaser selects the entitlement from defective fulfilment to be the defect removal, it can refuse the Seller's proposed method for the defect removal if it is considered insufficient, and define a suitable method for the defect removal' In such case the Seller is not entitled to any additional costs.

## **X. Insurance**

1. The Supplier is obliged to have the agreed liability insurance for the property damage coverage in relation to the performance of the Supply subject matter, at least until due handover and acceptance of the Supply subject matter by the Client, with the insured amount at least 10,000,000 CZK and with the coinsurance of the Supplier of maximum 10 % value of the insurance event. Failure to fulfil this obligation shall be considered a substantial breach of the Contract.
2. The Supplier must submit a record proving the insurance existence, eventually the respective insurance contract upon the request of the Client within the deadline determined by the Client.



## **XI. Contractual Penalties**

1. If the Supplier is delayed in delivering the Supply subject matter to the Client, it undertakes to pay a contractual penalty to the Client amounting to 0.2 % of the Supply subject matter price for every commenced day of the delay.
2. In case of the Supplier's delay in the defect removal requested by the Client during the warranty period within the agreed deadline, the Client is entitled to contractual penalty amounting to 1,000 CZK for every defect and for every day of the respective delay.
3. In case of violating the obligation of the Supplier to provide spare parts and consumption material specified in article IX.7 hereof, the Client is entitled to contractual penalty amounting to 100,000 CZK for every such violation.
4. In case of the Supplier's delay to arrive to the performance location of the servicing intervention within the Out-of-warranty service, the Client is entitled to contractual penalty amounting to 500 CZK for every commenced hour of the delay.
5. If the Supplier's violation of regulations causes an infliction of penalty to the Client by external administration or inspection bodies, the Supplier is obliged to pay the penalty to the Client. Such case shall be considered a substantial breach of the Contract.
6. The enforcement of the claim or payment of the contractual penalty does not affect the Client's right for the compensation of the proven damage caused by the Supplier to the Client by failure to fulfil the obligations of the Supplier under this Contract or under law, in the full amount. The Supplier shall pay the damages using a method and within the deadline notified by the Client in written notice.
7. The contractual penalties and damages will be charged by independent payment records. The Supplier is obliged to pay the contractual penalty or pay the damages within 30 days from receiving the payment record issued by the Client.

## **XII. Confidentiality**

1. The Supplier and the Client are obliged to maintain confidentiality on all matters forming the business secret of the second contracting party, and also other data related to the second contracting party, which they received in relation with the fulfilment of this Contract, and also other data that the second party indicates as confidential. The Supplier and the Client must not, without the consent of the second contracting party provide or make the data accessible to other entities or use it for their own needs or for other entities (including the family members and close persons). It does not apply to generally known data.
2. The confidentiality obligation relates to the matters not commonly available in the respective business circuits, in particular:
  - The matters of business nature, in particular information on internal and economical situation and contractual partners of the second contracting party, information on services provided or used by the second contracting party,

information on business activities and business methods of the second contracting party,

- The matters of production nature,
  - The matters of technical nature.
3. If the obligation to maintain the business secret and confidentiality is violated, contrary to the terms of this Contract, it constitutes substantial breach of the Contract and the contracting party which violated the obligation shall pay to the second contracting party a penalty in amount of 50,000 CZK for every case of breach of the obligation. The payment of the contractual penalty does not affect or limit the right of the second contracting party for the compensation of damage that occurred in relation with the defined obligation breach.
  4. The above mentioned does not affect the right of the Client to publish the Contract within the full scope including all annexes on the profile of the Client.

### **XIII. Duration of the Contract**

1. The Contract becomes valid and effective on the day of signature by both contracting parties.
2. It is possible to withdraw from the Contract due to reasons stated by law and reasons stated by this Contract.
3. The Client is also entitled to withdraw from the Contract if the costs defined by the Contract are defined as ineligible by the Managing Body for the Operational Program Research, Development, and Education, or another inspection body, e.g. upon finding the matters below:
  - The Supplier's bid processing included the participation of the Client's employee or the member of the project implementation team or a person who, based on contractual relationship, participated in the preparation or assignment of the respective tender proceedings;
  - The Supplier's bid was processed in association with the Supplier and the person employed by the Client or member of the project implementation team or person who, based on contractual relationship, participated in the preparation or assignment of the respective tender proceedings;
  - Subcontractor for the Contract fulfilment is an employee of the Client, member of the project implementation team or a person who, based on contractual relationship, participated in the preparation or assignment of the respective tender proceedings.
4. Delay of the Supplier in handing over the Supply subject matter exceeding 30 days is considered a substantial breach of the Supplier's obligations under this Contract which entitles the Client to withdraw from the Contract by means of a notification of withdrawal in writing.
5. The termination of the Client or the Supplier with the legal successor does not cause the Contract termination but it passes to the legal successor.

6. In case of withdrawal from the Contract, the entitlements of the Client from the Supply subject matter defects, right to the damages and the right to contractual penalties remain valid.

#### **XIV. Force Majeure**

1. The contracting party is not in delay in the fulfilment of the obligation, if it is proven that the fulfilment was prevented temporarily or permanently by force majeure event, such as unforeseeable and insuperable obstacle that occurred independently on its will. It does not apply to the obstacle resulting from the situation of the contracting party which appeals to such circumstances, and to the obstacle that occurred when the party was already in delay in the fulfilment of the obligations.
2. Force majeure represents unforeseeable exceptional situations, strikes, lockouts, and other interruptions of industry, acts of public enemy, wars, declared or not, blockades, riots, demonstrations, epidemics, land slides, earthquakes, storms, lighting, floods, natural disasters, civil unrests, explosions and any other unforeseeable events, the contracting parties cannot affect and which are not manageable despite all care.
3. The contractual party whose rights and obligations under the Contract are affected by force majeure, must take all possible measures required to remove the inability to fulfil the obligations with minimum delay under this Contract.
4. If the contracting party caused damage by violating its obligation under the Contract, it shall be free from the damage compensation obligation if it is proven that the fulfilment was prevented temporarily or permanently by force majeure event, such as unforeseeable and insuperable obstacle, that occurred independently on its will. It does not apply to the obstacle resulting from the situation of the contracting party which appeals to such circumstances, and to the obstacle that occurred when the party was already in delay in the fulfilment of the obligations.
5. If any of the contracting parties assumes that the circumstances of force majeure occurred, which could affect the fulfilment of its obligations, it must immediately inform the second contracting party and define the details on the nature, probable duration, and probable effect of the circumstances. If the Client does not issue instructions in writing stating otherwise, the Supplier must continue in the fulfilment of its obligations in compliance with the Contract, if it can be justly required considering all circumstances, and it must seek all alternative tools for the fulfilment of obligations not prevented by force majeure. The Supplier must not use alternative tools unless instructed by the Client.
6. If the force majeure obstacle, causing the impossibility to deliver the Supply subject matter, lasts over 2 months, the contracting parties are entitled to agree on permissible Contract amendment in relation to the subject matter, price, and fulfilment period. In case of failure to conclude such agreement, both parties are entitled to withdraw from the Contract. The effects of withdrawal are valid on the day of the notification delivery.

## **XV. Final Provisions**

1. The Supplier is aware that the provider of the support within the Operation Program Research, Development, and Education is entitled to perform the inspection of the project goals' fulfilment within the project 'Development of Research Infrastructure CATPRO', including the inspection of the support use and the purpose orientation of the project costs utilisation in compliance with the Decision on the support provision no.: 16\_013/0001801-01, and in compliance with the Decision no. 11/2017 on the provision of 'Institutional support for long lasting conceptual development of research organisation based on the evaluation of achieved results'. The Supplier is aware that the support providers are entitled to perform financial inspection according to § 39 Act no. 218/2000 Coll., on the budget rules, as amended, and Act. no. 320/2001 Coll., on financial inspection in public administration, as amended. The Supplier is obliged to provide full cooperation during the inspection performance by the support providers and observe all instructions of the providers or the Client in relation with the inspection, particularly provide access to the workplace, to persons participating in the Contract implementation, and to all documents, computer records, and devices forming a part of the Contract fulfilment or related to the Contract. The Supplier must maintain all documents, computer records, and other information related to the Contract fulfilment for the period defined by the legal regulations in the Czech Republic and by directly applicable regulations of the European Union, at least for the period of the project implementation and then for five (5) years after the project completion with the planned completion at the latest on 31.12.2020. The Supplier is obliged to ensure that the obligations as per this Contract article must be in the same scope fulfilled by potential subcontractor of the Supplier.
2. The Supplier is during the supply and installation of the Supply subject matter obliged to observe all legal regulations related to the occupational health and safety. The Supplier is further obliged to observe all legal norms, local regulations and rules related to the workplace, observing the safety, hygienic and fire regulations, including the supply location and the Supply subject matter installation. During the supply and installation of the Supply subject matter, the Supplier is obliged to observe the regulations related to work safety, in particular Act no. 309/2006 Coll., on the provision of other conditions for occupational health and safety.
3. The Supplier is obliged to mark the correspondence to be delivered to the Client with the Client's Contract number and the name of the Public Contract. The Client can return the unmarked correspondence to the Supplier. Potential related delay is to the detriment of the Supplier.
4. This Contract can be amended and cancelled only in writing and based on mutual consent of both contracting parties. Electronic form is not considered as a form in writing.
5. This Contract is executed in Czech and English languages, both language versions in four counterparts with the validity of the original; each contracting party shall receive two counterparts in each language version. In case of any discrepancies, the Czech version shall prevail.

6. All legal relationships arising out of the Contract and untreated in this Contract are subject to Act no. 89/2012 Coll., Civil Code, as amended, potentially to other respective legal regulations.
7. The following Annexes represent an integral part of the Contract:
  - Annex No.1 – Specification of the Supply subject matter – **to be added by the bidder**
  - Annex No.2 – Description of the servicing activities provided – **to be added by the bidder**
  - Annex no. 3 – Conditions for the entry and movement in Chempark Záluží
  - Annex no. 4 – Services provided by the site manager of Chempark Záluží

In .....on .....

In .....on .....

.....  
Supplier

.....  
Ing. František Svoboda  
*Chairman of the Board of Directors*

.....  
doc. Ing. Jaromír Lederer, CSc.  
*Vice-chairman of Board of Directors*

## Identification of the bidder

Name / Business company: [to be added by the bidder]

Place of business / head office: [to be added by the bidder]

Identification No.: [to be added by the bidder]

Tax ID: [to be added by the bidder]

Bank details: [to be added by the bidder]

Account number: [to be added by the bidder]

Scope of business / activities: [to be added by the bidder]

Name of the register,  
where the bidder is recorded: [to be added by the bidder]

Record reference: [to be added by the bidder]

Name of the court or another body,  
where the register is administered: [to be added by the bidder]

Person authorised  
to act on behalf of the bidder: [to be added by the bidder]

Contact person: [to be added by the bidder]

Telephone of the contact person: [to be added by the bidder]

e-mail of the contact person: [to be added by the bidder]

The bidder is considered to be a small or medium company  
According to the recommendation of Commission 2003/361/ES: [YES/NO]

In [to be added by the bidder] on [to be added by the bidder]

---

[name of the bidder - to be added by the bidder]

[Name and surname of a person authorized to act on behalf or for the bidder - to be added by the bidder]

[function or authorisation - to be added by the bidder]

Appendix: Power of attorney of a person authorised to act on behalf of the bidder [the bidder shall preserve this note solely in case it is represented by a person authorized based on power of attorney]

## Declaration as regards to the technical qualification requirements

### The list of persons responsible for the provision of the respective activities as per article 4.3.2 of the tender documentation

Company [to be added by the bidder], Identification No.: [to be added by the bidder], with its registered office [to be added by the bidder]<sup>1</sup> as the bidder in the public contract proceeding for below-threshold public contract titled '*Continual Distillation*' announced by the Contracting Authority **Unipetrol Centre for Research and Education, a. s.**, with its registered office at Revoluční 84, 400 01 Ústí nad Labem, Identification No.: 622 43 136, hereby declares it has a servicing team available for the public contract fulfilment, whereby the team member will be [name and surname TO BE ADDED], who:

- Is authorized to work on electrical devices up to 400 V as per the Regulation No. 50/1978 Coll. on professional eligibility in electrical technology, as amended, at least at level 'Workers for independent activity' pursuant to § 6 of the Regulation or similar qualification comparable within EU,
- Has practise in servicing activity for the defined type of device in minimum duration of 1 year,
- Is authorized to perform servicing activities for the machine type corresponding to the required distillation apparatus; and
- Is able to communicate in Czech, Slovak, or English language.

The bidder declares that the above member of the servicing team is [the employee of the bidder/subcontractor of the bidder/ employee of the subcontractor with name, Identification No., registered office – the bidder shall define one of the alternatives; in case of subcontractor's employee, the bidder shall define the identification of the subcontractor].

In [to be added by the bidder] on [to be added by the bidder]

---

[name of the bidder - to be added by the bidder]

[Name and surname of a person authorized to act on behalf or for the bidder - to be added by the bidder]

[function or authorisation - to be added by the bidder]

---

<sup>1</sup> If the sample wording of the bidder's identification does not comply with its legal form, the bidder shall correct and add identification data compliant with its legal form. This note shall then be deleted.

## Declaration as regards to the technical qualification requirements

### List of significant supplies

As per article 4.3.1. Tender documentation

Company [to be added by the bidder], Identification No.: [to be added by the bidder], registered office at [to be added by the bidder]<sup>2</sup> as the bidder in the public contract proceeding for below-threshold public contract titled '*Continual Distillation*' announced by the Contracting Authority **Unipetrol Centre for Research and Education, a. s.**, with its registered office at Revoluční 84, 400 01 Ústí nad Labem, Identification No.: 622 43 136, hereby declares that in the last 3 years before the commencement of the public contract proceeding (i.e. the date of publishing the notice) it implemented at least one supply with the subject matter being the supply of a device similar to the required Distillation Apparatus for continual distillation at minimum value 2 million CZK excluding VAT, which is:

Name, Identification No., registered office of the Client	Contact person of the client with telephone number or email	Name / identification of significant supply	Description of the supply subject matter	Implementation period
[to be added by the bidder]	[to be added by the bidder]	[to be added by the bidder]	[to be added by the bidder]	[to be added by the bidder]

In [to be added by the bidder] on [to be added by the bidder]

[name of the bidder - to be added by the bidder]

[Name and surname of a person authorized to act on behalf or for the bidder - to be added by the bidder]

[function or authorisation - to be added by the bidder]

<sup>2</sup> If the sample wording of the bidder's identification does not comply with its legal form, the bidder shall correct and add identification data compliant with its legal form. This note shall then be deleted.



## Description of the servicing activity provision

Name of the machine: [to be added by the bidder]

Warranty and out-of-warranty service of the above defined machine is provided by the servicing technician who are authorised for the maintenance and service of the machine. The supplier is obliged to maintain a servicing team, for the contract fulfilment period and for 6 years from accepting the fulfilment as per the contract, where at least one member:

- Is authorized to work on electrical devices up to 400 V as per the Regulation No. 50/1978 Coll. on professional eligibility in electrical technology, as amended, at least at level ‘Workers for independent activity’ pursuant to § 6 of the Regulation or similar qualification comparable within EU,
- Has practise in servicing activity for the defined type of device in minimum duration of 1 year,
- Is authorized to perform servicing activities for the machine type corresponding to the required distillation apparatus; and
- Is able to communicate in Czech, Slovak, or English language.

Prices for the servicing interventions and binding deadlines are defined by valid legislation and binding contract draft forming Annex no. 2 of the tender documentation for below-threshold public tender titled ‘Continual Distillation’.

Warranty and out-of-warranty servicing requirements can be applied by the client by e-mail, telephone, and in writing using the contacts below:

[The bidder shall add names, emails, telephone and address of contact persons]

In [to be added by the bidder] on [to be added by the bidder]

---

[name of the bidder - to be added by the bidder]

[Name and surname of a person authorized to act on behalf or for the bidder - to be added by the bidder]

[function or authorisation - to be added by the bidder]

## **UNIPETROL RPA**

**Safety (work safety, health protection, fire safety, prevention of serious emergency, transport of hazardous items, security of the premises), and environmental protection**

**Conditions of the Client for the activities of the contractor and subcontractors:**

### **A. General conditions**

1. Provide safety, fire protection, health protection, work hygiene, prevention of serious accidents, transport of hazardous items (ADR/RID), protection of the premises and environmental protection, and perform works in compliance with the provisions of generally binding and other regulations, technical standards, internal standards of the client and the respective business contracts.
2. Read the binding standards and information defined on internet address of UNIPETROL RPA, s.r.o. <http://www.unipetrolrpa.cz/cs/sluzby-areal/chempark-zaluzi/zavazne-normy-a-informace/>, fulfil the provisions of the standards and information during all activities in Chempark Záluží, and ensure provable acquaintance of the employees with the respective binding standards and information within the scope of performed activities prior to the work commencement.
3. Read further documents, requirements, and information which must be fulfilled, their handing over is provided physically or accessible by sharing via electronic form, and ensure provable acquaintance of the employees, and fulfil the provisions of the documents, requirements, and information during all activities implemented in Chempark Záluží.
4. Pass all requirements of the client to its suppliers, and upon request provide the list of all suppliers and their employees who perform/ will perform activities for the contractor based on the Order/Contract.
5. Undertake inspections and audits organised by the client for the purpose of verifying the binding conditions related to individual areas of the integrated management system, provide required information during the activities, and immediately implement the agreed corrective measures.
6. Observe all decisions of persons authorized to perform the inspection activities, and upon their instruction immediately stop works in a case of danger to life and health of individuals, and possible exceptional events and damages.
7. Maintain clean workplace during the contract fulfilment, remove all caused leaks in the environment and damages at its costs, including the locations outside its workplace.

### **B. Waste handling.**

8. Unless the respective business contract stipulates otherwise, if waste occurs in the premises during the contractor's activity, the contractor will be considered as its producer.
9. The contractor must handle waste at its costs and in compliance with the legal provisions on waste, i.e. provide recycling, transport to the final utilisation location or waste removal including other related activities. The removal or use of waste must be contractually provided by means of authorised person as per Act on waste. The contractor is further obliged to:
  - a) Own or hire vessels for the collection of waste compliant with the technical state and marking to the adequate waste.
  - b) Never store waste from the activities in the collection vessels of other entities without their former consent.

- c) Never use outdoor or indoor areas for temporary storage of waste without written consent of the district manager.
- d) Ensure prevention of damage to environment or waste leaks in the environment during waste collection. It is also obliged to mark the collection place adequately, i.e. as per Regulation No. 383/2001.
- e) Never place waste outside the collection devices (which must be marked in compliance with applicable regulation) with the exception of temporary storage of contaminated soil, non-contaminated metal scrap, and the construction waste prior to its removal for final use or removal.
- f) Hand over, unless stated otherwise by the contract, all usable waste (metal, plastics, paper, waste oil) produced during the work implementation to the place defined by the contractual partner. It applies for the contractor.
- g) Hand over the waste solely to persons authorized to operate the device for the waste utilisation, their removal, collection or purchase.
- h) Have the consent of the respective state administration body for handling of dangerous waste.
- i) Submit the decision of District hygienic station in Most for handling waste with the content of asbestos (if such waste is produced) to the contractual partner.
- j) Prove that the applied vehicles for transport of hazardous waste in above limit amounts as per ADR regulations are equipped and marked in compliance with the regulations, and the drivers of the vehicles are trained adequately.
- k) Have the respective authorisations for the removal or use of waste produced during the business activity in the premises. They must be issued by state administration bodies (Regional office, Municipal office - Environmental Department, Trade Body).
- l) Manage the administration of waste within the legally specified scope of Act on waste and the relevant bylaws. It applies for the waste producer.
- m) Handover as a part of records on the completion and work acceptance by the contractual partner, the copy of the records used by the contractor to prove the method of waste removal or use (weight tickets and registration sheets for the transport of hazardous waste). The tenant is obliged, at any time upon request of the contractual partner (event. HSE&Q), to submit the records related to the removal or use of waste – i.e. continual registration of waste, weight tickets, and annual reports to the respective municipal office or magistrate).
- n) Perform the waste transport to the final disposal or use solely via gate no.5 (Minerva). It is necessary to have appropriately completed and confirmed pass „Pass via gate no.5“. This must be requested from the contractual partner together with the confirmation of waste production. All above defined forms are available on <http://www.unipetrolrpa.cz/cs/sluzbv-areal/chempark-zaluzi/zavazne-normy-a-informace/>. Provide legally required records for waste handed over for final removal or use (for hazardous waste, it is necessary to provide the identification sheet for hazardous waste, registration sheet for hazardous waste transport, the record on physical-chemical properties of waste, etc.).

### **C. Air protection**

10. In a case of emergency leak in the operating device, the contractor operating the source of contamination in the premises as per act on atmosphere protection, is obliged to:
  - Immediately inform the Department of the Operation Production Control (3111/2111) on the leak. State the contact to the competent employee and his telephone number.
  - Send the copy of a report on the emergency evaluation to HSE&Q (431, fax

476164906) and specified corrective measures submitted to Czech Environmental Inspection immediately after their completion.

11. During the notified regulation levels, the contractor/tenant must observe the instructions of the Department of Operation Control as per "Regulation order SVRS, applicable for UNIPETROL RPA".

#### **D. Old ecological burdens and water protection**

12. The planned activities when excavation of soil is expected (construction waste) in amount exceeding 30 m<sup>3</sup> must be reported during the selection of construction site, at the latest within 70 calendar days prior to the commencement of land (demolition) works, to the department HSE&Q (tel. 2617) pursuant to the Directive 372 and observe its provisions.
13. If during the activities the drilled is damaged or destructed, report this fact immediately to HSE&Q, including the specification of the guilty party. If the guilty party of the damage or drill destruction cannot be found, the costs for the repairs of the drill or completion of spare drill will be paid by the company which administers the area as per Directive 704 where the damaged or destroyed drill was present. Repair or replacement of the drill will be provided by HSE&Q in cooperation with the company Aquatest.
14. While handling with harmful substances or substances with increased hazards (see Act no. 254/2001 Coll.) within the scope exceeding the amount specified by Decree of the Ministry of Environment no. 450/2005 Coll. (15 kg and above), prepare the plan of measures for cases of emergency (emergency plan for the protection of waters within the scope of activities relevant for chemical emergency related to the hazard or deterioration of ground and surface water quality or rock environment).
15. During handling of the halogen solvents (e.g. tetrachloroethylene, trichlorethen, chloroform) immediately request HSE&Q (tel. 2617) for the handling permission, ensure training of persons who get in contact with the substances, and manage the records of handling.
16. Secure locations of possible leak during while handling with hazardous substances (HS) with the collection vessels or collection emergency tanks (tubs) and suitable absorption tools.
17. Secure the HS warehouses with impermeable treatment against HS leak in ground water (e.g. impermeable base for the walls with increased threshold in access openings), fit is with intervention tools for catching possible leaks and leaks during handling (e.g. vessel for leaked HS, absorption tools, etc.), and suitable tools for pre-medical first aid and personnel hygiene.
18. During handling of hazardous substances for water, handle HS solely on reinforced and secured surfaces to prevent water contamination, do not cause risks to water in sewage system, and do not cause hazard to the quality of surface and underground water
19. Operate only such technological devices at the workplaces and perform activities which were duly discussed with the respective departments of the contractual partner subject to the issued permissions from state administration bodies (e.g. Energy service department – complementary contract) and HSE&Q (tel. 2617).
20. Drain waste water in the treatment device in the designated location and method by the decision of the respective state body based on the conditions defined in HSE&Q (tel. 2617) or complementary contract, observe the prohibition for their drainage in sewer, and the prohibition for unauthorized disposal in the premises or outside the premises of the company.
21. In the event of an accident that could endanger or impair the quality of underground or surface water or the rock environment, proceed in accordance with Directive 444/1 – i.e. to report a crash to the Production Control Division (3111/2111) or HZSP (3000). Moreover immediately remove the causes of an

- accident and its damaging consequences or at least minimise them.
22. Permit the inspection of used premises and land plots for the verification of the handling compliance with hazardous substances with valid legislation and internal directives, and provide required materials for the inspection.  
Noncompliance with the duties in the area of environment protection may constitute the reason for penalty of the contractor by the environmental authorities. Repeated breaching of the environment protection rules may constitute a ground for withdrawal from the contract.
  23. Drainage of water in the sewerage system may only be carried out upon the approval of the sewerage system owner.
  24. Water consumption from underground distribution systems and hydrants may only be carried out with the consent of the Client.

#### **E. Safety, Occupational health and safety (OHS), fire protection (FP)**

The contractor undertakes:

25. To carry out all works solely by professionally and medically eligible employees.
26. Become acquainted with possible risk to health and life of persons related to Chempark Záluží and abide by measures specified by documents stated on address <http://www.unipetrolrpa.cz/cs/sluzby-areal/chempark-zaluzi/zavazne-normy-a-informace/>, (e.g. provide employees with the specified PPE, provide the equipment for the supplier's employees and persons working as independent entrepreneurs, who will perform the activities, and inspect their application during work).
27. Ensure OHS for persons working as independent entrepreneurs who will perform the activities related to the Order/ Contract identically to its own employees, and ensure the insurance for the persons for cases of their physical harm or death related to the contractor's work performance.
28. Upon request, provide the Client with the records on professional and medical eligibility of all persons to be used for the performance of activities within this Order/ Contract.
29. Provide the client with information in writing on the risks resulting from the character of its works which can cause hazard to the client's employees health and safety, eventually other persons present in the Client's premises.
30. Ensure the presence of employees, employees of its suppliers, and persons working as independent entrepreneurs who will perform the activities, at the initial and continual training of OHS and FP, and other training required by the Client.
31. In case of employing foreign state citizens ensure that every working group will include at least one employee able to translate and ensure the provision of information during the working activities and during the solution of exceptional situations.
32. Observe the provisions in the workplace handover protocol.
33. Ensure safety of all persons present on the accepted workplace with contractor being aware thereon.
34. Ensure the control of the work process, require and inspect the observing of legal and other regulations, technical standards, and all regulations and requirements specified by the contract by its employees and employees of contractors.
35. Provide coordination of the activities of the employees and supplier's employees, eventually other subjects, if defined within the workplace handover, in the plan for the workplace safety provision or within the Work Permission.

#### **F. Transport of hazardous items**

36. If the Contractor requires to transport hazardous items in above-limit amount to the company premises for the work implementation subject to ADR Agreement and/or RID policy (by the employees, potentially employees of the contractual

transport provider) it must provide for their transport to the premises the fulfilment of all annexes to ADR Agreement and/or RID Policy (e.g. the obligations fulfilment of the main and other transport participants of hazardous substances, the application of approved packages for the transport of hazardous substances, appropriate marking of packages and vehicles with safety marks, orange tables and other specified marks in the required design, certification for persons/ vehicles for the transport of hazardous items, the provision of safe unloading and safe location of items, reporting of potential accident during the transport in the premises, and processing, implementation, and use of transport safety plan for high risk hazardous items).

**Obligations of the Client for the activities of the contractor and subcontractors:**

37. Provide the Contractor's employees, the employees of the subcontractors and persons working as independent entrepreneurs with the initial and subsequent safety training, potentially other training resulting from the provision of the safety conditions.
38. Provide the Contractor with the organisation and control standards of the Client (not published on the web address as per article 2 General conditions), observing of which will be required from the Contractor in regard to the character of its activities, in printed, electronic form (CD, DVD, sharing, etc.).
39. Record the workplace handover including the specification of conditions for the work permit issuance, and the provision of FP conditions and social and hygienic conditions.
40. The unified system of first-aid medical assistance specified in relation to the identified risks of possible hazard to life and health of persons must be provided.
41. Acquaint the contractor with the system of stations for possible contacting of first-aid medical assistance.
42. Ensure fire protection by means of fire brigade.
43. Define the obligations of the operator for restricted lifting devices applied by the contractor in the operation plants owned by the client, provide the lifting technology installed in the operation plants for the authorized crane operators of the client.
44. Enable the entrance for the contractor's vehicles to the workplace under the conditions specified on the web address as per article 2 General Conditions.
45. Acquaint the Contractor within the required scope with the emergency plan for the production plant/ department with the respective evacuation locations and required behaviour in case of exceptional events in the production plant/ department or its vicinity.
46. Provide the Contractor with required information and advisory for processing the emergency instructions/ evacuation plans.

**Sanctions within the safety area**

47. Violation of the regulations in the safety area is resolved in compliance with directive S 402/1 Sanctions in the safety area, repeated violation of safety regulations is considered as material breach of the contract and it can state a ground for withdrawal from the contract by the client.

 <b>Unipetrol RPA</b> <b>ORLEN GROUP</b>		<b>Contract on Works No:</b>	
<i>Client:</i>	UNIPETROL RPA, s.r.o.	<i>Client's registration number:</i>	
<i>Contractor:</i>		<i>Contractor's registration number:</i>	

## Services of the client

THE CLIENT will provide all required agents and energy for payment to the defined construction site borders under the conditions below:

The selected CONTRACTOR will conclude independent business contracts for power supplies and auxiliary services to be used during the performance of construction or assembly works, and in the restricted construction site device for the completion of the work subject matter within the concluded contractual relations. Technical and business conditions of independent contracts must be agreed with individual administrators. The conclusion of required contracts will be provided by the selected contractor prior to the work commencement or prior to the commencement of the services and requirements resulting from the performance of the work subject matter.

## Services provided by means of Customer Centre of Chempark

At the defined workplace it is possible to conclude only one contract for the rent of premises, locations, and all required and available services. Contracted rent and services are invoiced monthly in one invoice. Necessary information on the provided services including detailed pricelists are available in Customer Centre.

Contact: Jana Korelová tel.no.: 47-616-4154, MT: 736505391  
 Jindřiška Šplíchalová tel.no.: 47-616-4215, MT: 736505392  
 email: [najmy.sluzby@unipetrol.cz](mailto:najmy.sluzby@unipetrol.cz)

If the requirement specification requires necessary technical information on the respective service, it is possible to contact the persons below considering the character of the of the question:

## Services provided by means of Customer Centre:

- a) Rent (non-residential premises, land plots, related property - equipment)  
 Ing. Petr Klimeš tel.no.: 47-616-4002 [petr.klimes@unipetrol.cz](mailto:petr.klimes@unipetrol.cz)
- b) Entrance to the premises  
 Ladislava Mikešová tel.no.: 47-616-2497 [ladislava.mikesova@unipetrol.cz](mailto:ladislava.mikesova@unipetrol.cz)
- c) Telecommunication services  
 Ing. Jaroslav Fojtík tel.no.: 47-616-4001 [jaroslav.fojtik@unipetrol.cz](mailto:jaroslav.fojtik@unipetrol.cz)
- d) Services of centre for breathing technology  
 Tomáš Palička tel.no.: 47-616-4293 [tomas.palicka@unipetrol.cz](mailto:tomas.palicka@unipetrol.cz)
- e) Services of information technologies  
 Help Desk tel.no.: 47-616-6633 [helpdesk@unipetrol.cz](mailto:helpdesk@unipetrol.cz)
- f) Services of library  
 Ing. Miroslava Šulcová tel.no.: 47-616-2046 [miroslava.sulcova@unipetrol.cz](mailto:miroslava.sulcova@unipetrol.cz)
- g) Mail services  
 Ing. Jindřich Mužík tel.no.: 47-616-3920 [jindrich.muzik@unipetrol.cz](mailto:jindrich.muzik@unipetrol.cz)

 <b>Unipetrol RPA</b> <b>ORLEN GROUP</b>		<b>Contract on Works No:</b>	
<i>Client:</i>	UNIPETROL RPA, s.r.o.	<i>Client's registration number:</i>	
<i>Contractor:</i>		<i>Contractor's registration number:</i>	

- h) Sale of soda water  
 Ing. Jindřich Mužík                      tel.no.: 47-616-3920      [jindrich.muzik@unipetrol.cz](mailto:jindrich.muzik@unipetrol.cz)
- i) Logistic services
  - Freight services
  - Custom services
  - Weighing on central vehicle scales  
 Ing. Martin Jupa                      tel.no.:47-616-4354      [martin.jupa@unipetrol.cz](mailto:martin.jupa@unipetrol.cz)
  - Handling and storage services
  - Renting work clothing  
 Anna Pešičková                      tel.no.:47-616-2235      [anna.pesickova@unipetrol.cz](mailto:anna.pesickova@unipetrol.cz)
- j) Emergency vehicles, Vehicle hire, Washing and cleaning passenger vehicles, tyre-service  
 tel.no.: 47-616-5344
- k) Collection, removal, and use of waste  
 Jindřiška Šplíchalová                      tel.no.: 47-616-4215      [jindriska.splichalova@unipetrol.cz](mailto:jindriska.splichalova@unipetrol.cz)
- l) Technical supervision  
 Ing. Bohuslav Mach                      tel.no.: 47-616-2173      [bohuslav.mach@unipetrol.cz](mailto:bohuslav.mach@unipetrol.cz)
- m) Services of material test-room and corrosion  
 Ing. Bohuslav Mach                      tel.no.: 47-616-2173  
[bohuslav.mach@unipetrol.cz](mailto:bohuslav.mach@unipetrol.cz)
- n) Defectoscopy and diagnostics  
 Ing. Bohuslav Mach                      tel.no.: 47-616-2173      [bohuslav.mach@unipetrol.cz](mailto:bohuslav.mach@unipetrol.cz)
- o) The supply of technical standards  
 Ing. Pavel Dobrovský                      tel.no.: 47-616-6165      [pavel.dobrovsky@unipetrol.cz](mailto:pavel.dobrovsky@unipetrol.cz)
- p) The provision of reprographic and documentary services  
 Ing. Pavel Dobrovský                      tel.no.: 47-616-6165      [pavel.dobrovsky@unipetrol.cz](mailto:pavel.dobrovsky@unipetrol.cz)
- q) Geodetic services  
 Ing. Miloš Hezký                      tel.no.: 47-616-4539      [milos.hezky@unipetrol.cz](mailto:milos.hezky@unipetrol.cz)
- r) Sale of property (transport vehicles, tangible and intangible property)  
 Dana Kadlecová                      tel.no.: 47-616-5281      [dana.kadlecova@unipetrol.cz](mailto:dana.kadlecova@unipetrol.cz)

## 2. Consumption of electricity, steam, water

In order to ensure the respective energy, water, and technical gas supplies and services for wastewater treatment, it is necessary to contact the below defined business location where it is possible to receive required information on the supplies of energies and other media, on the materials required for the contract conclusion and on prices of individual agents, energy services and products.



 <b>Unipetrol RPA</b> <b>ORLEN GROUP</b>		<b>Contract on Works No:</b>	
<i>Client:</i>	UNIPETROL RPA, s.r.o.	<i>Client's registration number:</i>	
<i>Contractor:</i>		<i>Contractor's registration number:</i>	

Contact: Ing. Jitka Kadlecová tel.no.: 47-616-3639

email: [jitka.kadlecova@unipetrol.cz](mailto:jitka.kadlecova@unipetrol.cz)

### 3. Catering

DORA Gastro as.

Contact: Mr Jaromír Vitha – Operation Manager Záluží tel.no.: 47-616-3118

MT: 606628489 email: [jvitha@dora.cz](mailto:jvitha@dora.cz)

### 4. Railway track

UNIPETROL DOPRAVA, s.r.o.

Contact: Ing. Luděk Mizuň – Transport Department Manager tel.no.: 47-616-4081

email: [ludek.mizun@unipetrol.cz](mailto:ludek.mizun@unipetrol.cz)

### 5. Health care

Paracelsus, s.r.o.

Contact: Ing. Vítězslav Novák – Company CEO tel.no.: 47-616-5654

email: [novak@paracelsus.cz](mailto:novak@paracelsus.cz)